



OMEGA PUMP WITH CONTROLLER

CHARACTERISTICS

- **COMPACT DESIGN**
- **FOR MULTILINE AND PROGRESSIVE SYSTEMS**
- **10 OUTLETS FOR PUMPING ELEMENTS**
- **OPERATING TEMPERATURE**
-25 ~ +70 °C
- **RESERVOIRS**
With cartridge
400 cc (0.1 gal)
700 cc (0.18 gal)
With follower plate
1,2 l (1,2 gal)
- **OPERATING PRESSURE**
Progressive system: 280 bar (4061 psi)
Multi-line system: 200 bar (2900 psi)
- **12V DC and 24V DC**
- **LUBRICANTS**
NLGI 000 ÷ NLGI2
- **SUITABLE FOR INTERNET ON DROPSA DRUCS PLATFORM**
- **ADVANCED TOUCH SCREEN CONTROL SYSTEM**
- **TWO GENERIC INPUTS**

APPLICATIONS

- **CONSTRUCTION EQUIPMENT**
- **MACHINE TOOLS**
- **EARTHWORKS EQUIPMENT**
- **SMALL AND MEDIUM LUBRICATION SYSTEMS**

HIGH PERFORMANCE IN A COMPACT PUMP

AUTOMATIC OMEGA pump is the ideal multi-point electric grease pump for small and medium lubrication systems.

DropsA OMEGA Pump works simultaneously with progressive and multi-point systems.

MULTILINE SYSTEMS provides 8 lubrication points directly to the point, without distributors!

Thanks to the **2 PROGRESSIVE OUTLETS** this pump can feed more lube points, and the system can be expanded using more progressive distributors. Like all the progressive systems, it can be extended with the secondary lines.

Very compact, **AUTOMATIC OMEGA pump** is available with 2 different reservoirs, with **follower plate** or with **preloaded cartridge**.

OMEGA pump is the ideal solution for all small-medium size installations.

This version of the pump include an **electronic card** that allow to manage lubrication cycles, alarms and controls.

- *Can be used for construction equipment and all common vehicles*
- *Few points to lubricate*
- *Machine tools and all machines with small and medium lubrication systems*
- *Ideal for installation in small spaces thanks to its small size*
- *The best solution if you want to combine Multi-line and Progressive Systems*

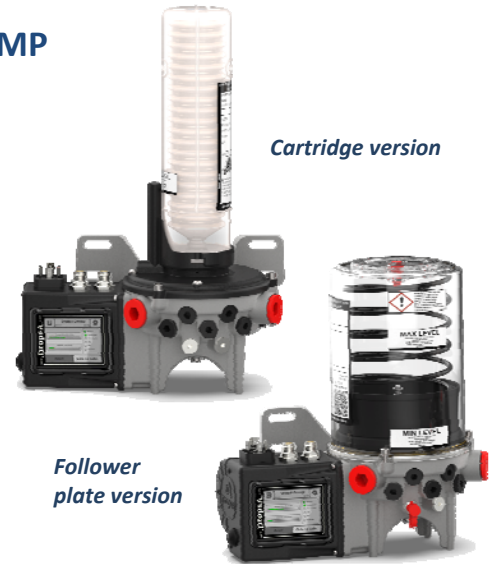

SETTING EXAMPLES

Systems with 33/Line pressure switch

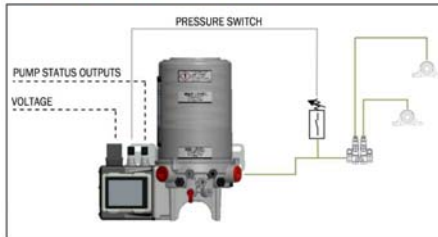

With this configuration, the lubrication phase is formed of a **single cycle** (Number of cycles: 1) that starts **every 6m 00s** (Interval Time: 6m 00s) and finishes once the **line pressure** is reached, which must occur within 30 seconds of the start of the lubrication cycle (Cycle Timeout: 30s). Otherwise, a cycle alarm is generated.

Progressive Systems

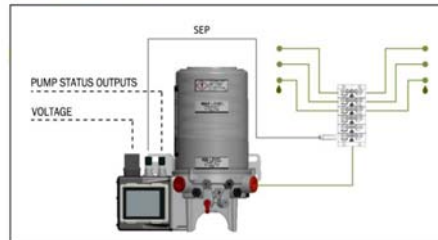

With this configuration, the lubrication phase is formed of a **single cycle** (Number of cycles: 1) that starts **every 2 pulse signals** (Interval Pulses: 2) arriving on **Input 1** (Input 1: Pulses Count). The lubricating phase finishes with the transition 0 → 1 → 0 (or 1 → 0 → 1) on Input 2 (Input 2: SEP/PROX), which must occur within 30 seconds of the start of the lubrication cycle (Cycle Timeout: 30s). Otherwise, a cycle alarm is generated.

Timed systems

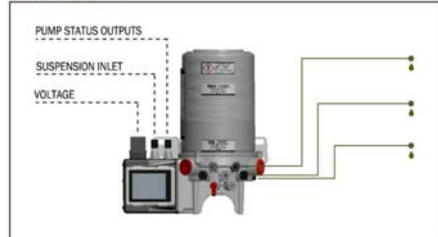

With this configuration, the lubrication phase is formed of **two cycles** (Number of cycles: 2) that start every 6m 00s (Interval Time: 6m 00s). The **two lubrication cycles**, with a duration of **30s each** (Cycle time: 30s), are separated by a **10s pause** (Pause between cycles: 10s). The lubrication phase finishes when the end of the second lubrication cycle is reached (Number of cycles: 2). Input 1, if activated, switches the pump into *Suspension* mode (Input 1: Suspension.) This mode suspends the operation of the pump for the duration for which Input 1 is active. After deactivation of Input 1, the pump's operation resumes from the point where it was suspended.

Multi-line systems

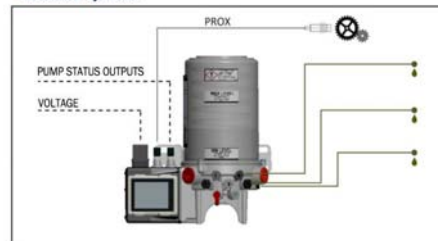

With this configuration, the lubrication phase is formed of a **single cycle** (Number of cycles: 1) that starts **every 6m 00s** (Interval Time: 6m 00s) or **every 10 pulse signals** (Interval Pulses: 10) arriving on Input 1 (Input 1: Pulses Count). The lubrication phase finishes on the achievement of 2 complete revolutions of the pump motor (Cycle Rotations/Pulses: 2).



OMEGA PUMP WITH CONTROLLER

THECNICAL CHARACTERISTICS

RPM			20
Flow rate	Multi-line	cm ³ /min [in ³ /min]	0,005 - 0,01 - 0,015 - 0,025 - 0,05 [0.0003 - 0.0006 - 0.0009 - 0.0015 - 0.003]
	Progressive		2,8 - 5,2 [0.17 - 0.31]
	Progressive Reg.		0,4 ÷ 2,8 [0.02 ÷ 0.17]
Operating pressure	Multi-line	bar [psi]	200 [2900]
	Progressive		280 [4061]
Outlets (pumping elements)	Multi-line	N°	8
	Progressive		2
Delivery connection (pumping element outlet)	Multi-line	Tipo	G1/8"
	Progressive		G1/4"
Operating temperature			-20 ~ +70 [-4 ~ +158]
Reservoir	Follower plate	l [gal US]	1,2 [0.32]
	Cartridge		0,7 [0.18] 0,4 [0.1]
Lubricants			Grease 000 ÷ 2

CONNECTOR BASES TECHNICAL CHARACTERISTICS

Power supply voltage	VDC	12 - 24
Working temperature	°C [°F]	-25 ÷ +70 [-13 ÷ +158]
Storage temperature	°C [°F]	-30 ÷ +80 [-22 ÷ +194]
Hardware characteristics		Motor overload restriction Power transient protection Protection against power supply disturbances (spikes) Remote alarm signalling Cycle control via reed
2 input signals (self-configurable)	PNP - NPN	Self-powered from the same connector V sensors = Power supply voltage - A = 1A max)
2 Output signals (configurable)	PNP - NPN	V outputs = Power supply voltage - A = 1A max per output

REMOTE CONTROL

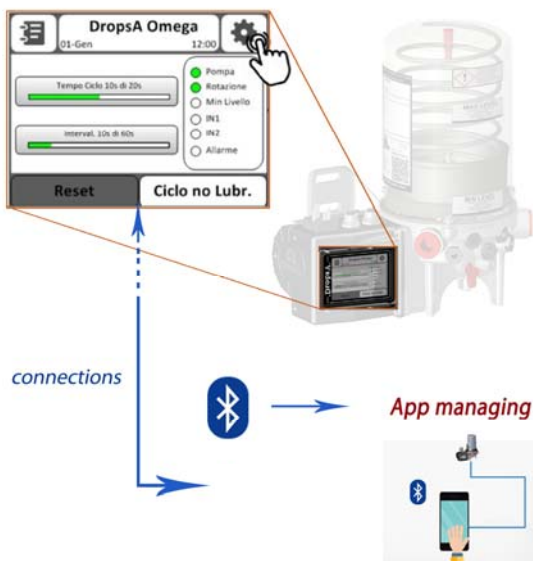

- **INTUITIVE TOUCH SCREEN DISPLAY**
- **2 PROGRAMMING LEVELS**
- **REMOTE MANAGEMENT WITH BLUETOOTH AND WI-FI**

CONNECTIONS

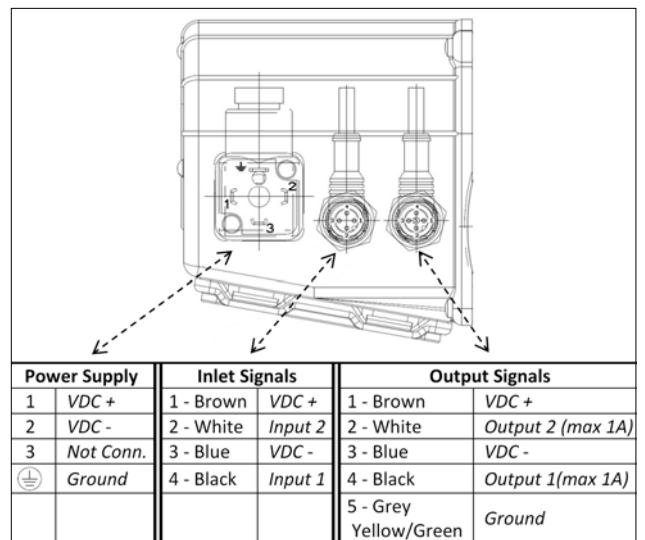



OMEGA PUMP WITH CONTROLLER

DIMENSIONS (NOT TO SCALE)

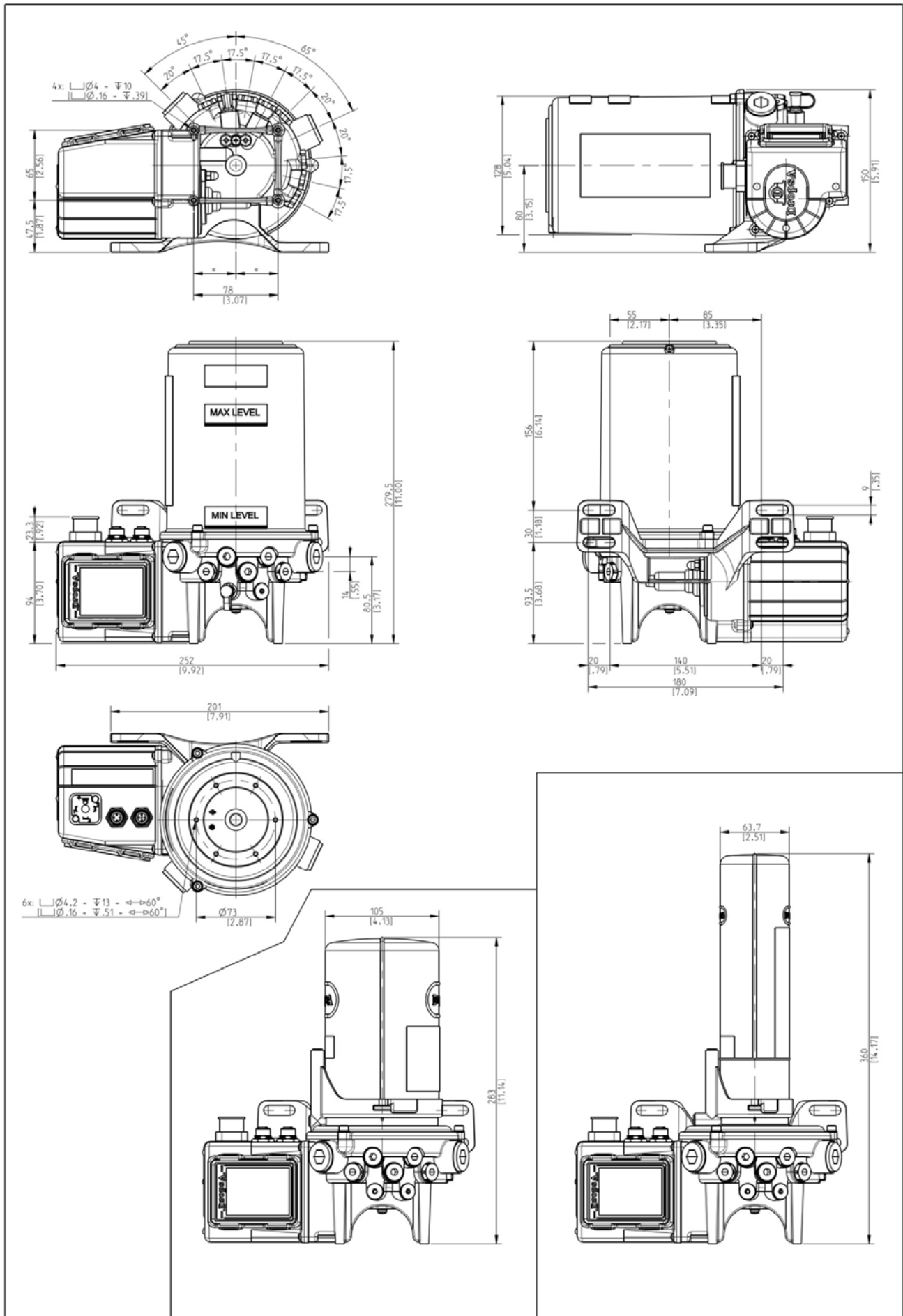



OMEGA PUMP WITH CONTROLLER

ORDERING INFORMATIONS

	RESERVOIR	VOLTAGE	PART NUMBER
OMEGA PUMP	WITH FOLLOWER PLATE	12VDC	0888586
		24VDC	0888587
	WITH CARTRIDGE 700CC*	12VDC	0888590
		24VDC	0888591
	WITH CARTRIDGE 400CC*	12VDC	0888588
		24VDC	0888589

*The cartridge must be ordered separately

PUMPING ELEMENTS	FLOW RATE	PART NUMBER
FOR PROGRESSIVE SYSTEMS	2.8 cm ³ /min (With By-pass) (0.17 in ³ /min)	0888058C
	2.8 cm ³ /min (0.17 in ³ /min)	0888156
	5.2 cm ³ /min (0.31 in ³ /min)	0888391
	0.4 ~ 2.8 cm ³ /min (0.02 ~ 0.17 in ³ /min)	0888555
FOR MULTI-LINE SYSTEMS	0,005 cm ³ / rev	0888550
	0,01 cm ³ / rev	0888551
	0,015 cm ³ / rev	0888552
	0,025 cm ³ / rev	0888553
	0,05 cm ³ / rev	0888554

ACCESSORIES

	DESCRIPTION	PART NUMBER
	DROPSA BLUE cartridge NLGI 0 grease - 400cc **	0888573
	DROPSA BLUE cartridge NLGI 0 grease - 700cc **	0888576
	External By-Pass with pressure gauge	0888572
	External By-Pass without pressure gauge	0888163
	Reservoir maximum level sensor kit	3133644
** For the first refill, order two cartridges		

DESCRIPTION	PART NUMBER
Cable with M12 <-> DIN43650(A) connectors for automatic Vent valve	0039119
Connector M12 - 90° 4Pins Male cable 3 m	0039080
Connector M12 - 90° 5Pins Male cable 3 m	0039082
Connector M12 - Straight 4Pins Male to be cabled	0039171
Connector M12 - Straight 5Pins Male to be cabled	0039056
Connector M12 - 90° 4Pins Male to be cabled	UE-CVPV038
Connector M12 - 90° 5Pins Male to be cabled	UE-CVPV039
Connector M12 A Y 0.3 m 1-Male (Pump Side) to 2-Female (Inputs Side)	UE-CVPR031
DIN 43650 connector without cable	0039976
M12 cap	UE-COPV036

Info Distributor:

C2283PE WK 11/17

DropsA products can be purchased from Dropsa subsidiary and Dropsa sales representatives, visit www.dropsa.com/contact or contact us sales@dropsa.com